

Installation Instructions

Q7 2007 ➤

Body
DVD player seat retainer
Edition 10.06

Contents

1	Parts allocation and tools	1
1.1	Parts allocation	1
1.2	Tools	2
2	Dismantling and assembling sequence	4
2.1	Before changing a wheel	4
2.2	Electrical connections, cable routing to the seats	4
2.3	Mount retainer on seat and connect cables	6
2.4	Final checks	8

1 Parts allocation and tools

1.1 Parts allocation

The required parts for mounting a DVD player to one of the front seats is included in this mounting set.

You will also require a parts set „2 plastic sockets + 1 cover for power socket“ corresponding to the colour of the interior.

To mount a second DVD player, you will require a second mounting set „RSE system Audi Q7 retainer for tablet player“ and a second parts set „2 plastic sockets + 1 cover for power socket“.

– Before mounting, check the mounting set for completeness.

RSE system Audi Q7 retainer for tablet player -4L0 051 700 A-

Quantity	Part No.	Description
1		Installation instructions in the following languages: German, English, French, Italian, Spanish, Swedish, Czech, Dutch, Japanese, Chinese
1	4L0 063 764	Retaining plate with retainer 12 V-power supply
1	4L0 063 747 1AD	Tablet player retainer (plastic) with lug
1	4L0 063 748 A	Connecting wire seat - player
1	4L0 063 748 B	Seat cable with 12 V socket
1	4L0 063 748 C	Connecting wire passenger - driver
1	4L0 063 748 E	Connecting cable with relay
2	N 907 505 03	Bolt M6x25
2	N 023 002 13	Nut M6
30	N 106 478 01	Cable ties black
1	N 104 009 01	Cable ties black
1	4B0 971 955	Flat contact housing
1	191 971 790 A	Foam tube
2	3B0 971 790	Foam tube
1		Template

2 plastic sockets + 1 cover for power socket soul -4L0 051 745-

Quantity	Part No.	Description
2	4L0 063 744 1AD	Plastic socket ZSB soul
1	4L0 063 745 1AD	Cover cap for 12 V socket soul

2 plastic sockets + 1 cover for power socket grey -4L0 051 745 A-

Quantity	Part No.	Description
2	4L0 063 744 D89	Plastic socket ZSB grey
1	4L0 063 745 D89	Cover cap for 12 V socket grey

**2 plastic sockets + 1 cover for power socket beige
-4L0 051 745 B-**

Quantity	Part No.	Description
2	4L0 063 744 6AJ	Plastic socket ZSB beige
1	4L0 063 745 6AJ	Cover cap for 12 V socket beige

1.2 Tools

**Special tools, testers, measuring instruments and auxiliary items
required**

- ◆ airbag adapter -VAS 6235-

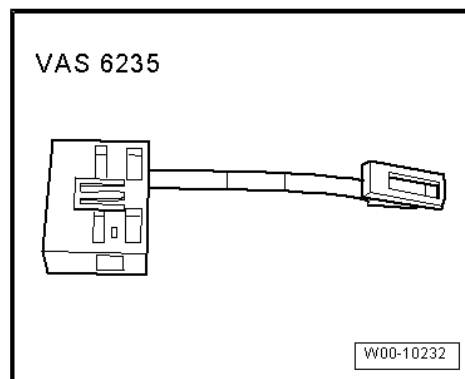

- ◆ airbag adapter -VAS 6280-

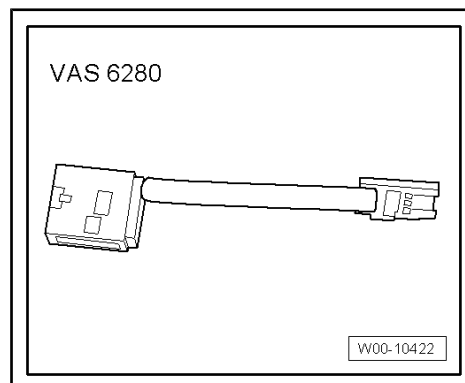

- ◆ Release tool set -VAS 1978/35-

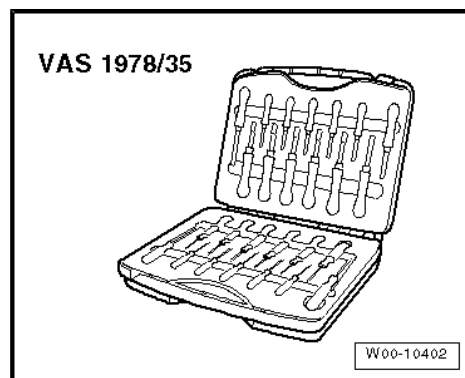

◆ Removal wedge -3409-

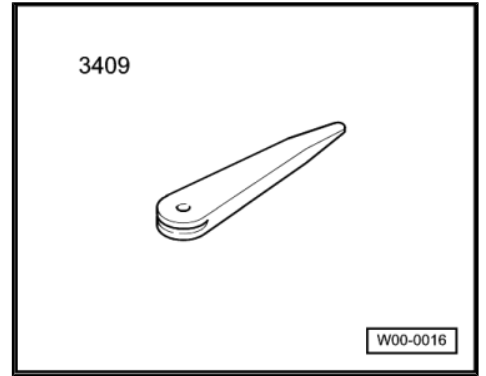

2 Dismantling and assembling sequence

2.1 Before changing a wheel

- Remove front left seat → Body; General body repairs, interior Rep.-Gr. 72 ; Seat frame.
- Remove front right seat if a retainer is to be mounted on it → Body; General body repairs, interior Rep.-Gr. 72 ; Seat frame.
- Unscrew the front securing bolts from the front left seat frame and unfold the seat frame.
- Remove the backrest cover of the removed seat/s → Body; General body repairs, interior Rep.-Gr. 72 ; Seat frame.
- Remove front left and rear right sill panels → Body; General body repairs, interior Rep.-Gr. 70 ; Trim panels, Insulation; Trim panels.

2.2 Electrical connections, cable routing to the seats

- Battery disconnected

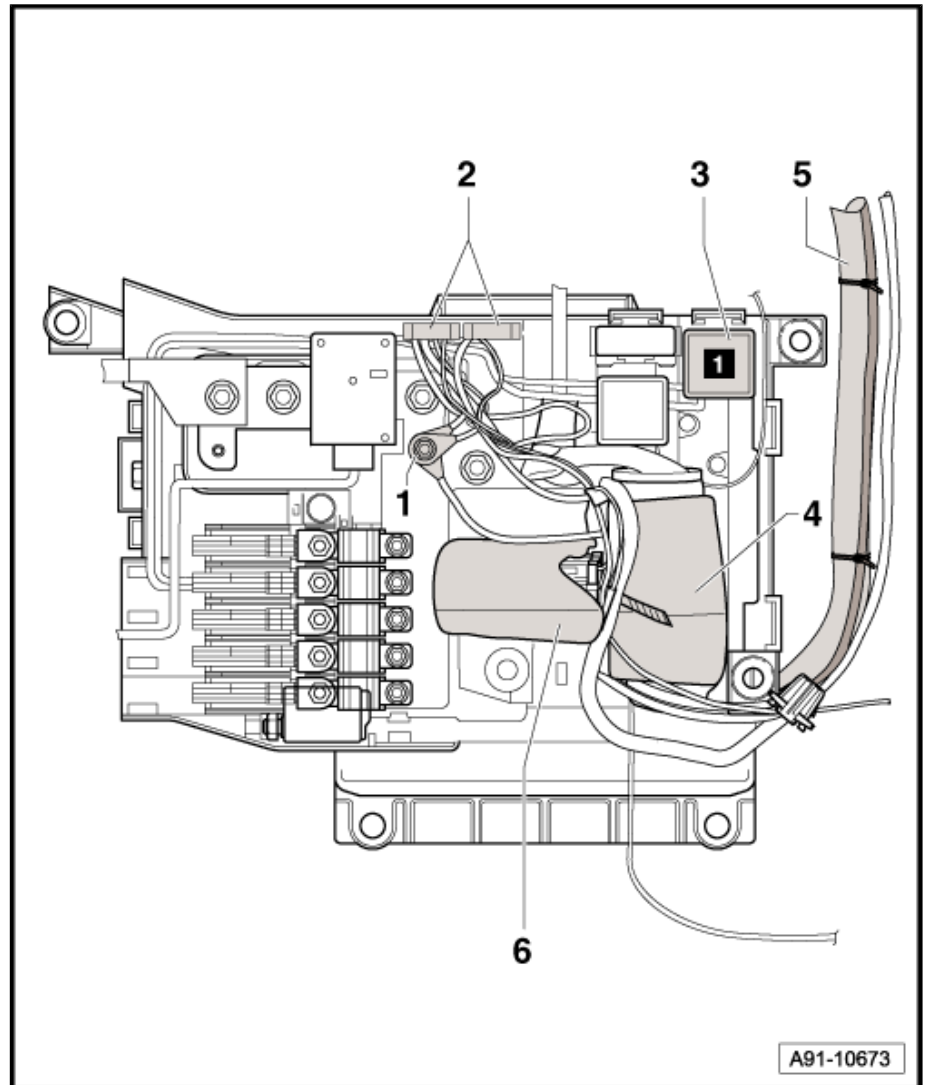

- Connect the current supply of the DVD player (red cable) to the connection -1- on the relay and fuse carrier under the driver's seat.

Specified torque 4.5 Nm

- Place the fuse holder on the plug positions -2-.
- Pull the relay -3- and the base out of the retainer.
- Unlock the black cable in the relay base chamber 2 and pull it out of the housing.
- Place the cord shoe of the connecting cable in chamber 2 and check for secure fit.
- Place the cord shoe of the vehicle cable set in the supplied connector housing -4- in the same way as the connector of the connecting cable and check for secure fit.
- Pull the foam tube -3B0 971 790- over the connector housing.
- Connect the connector housing and check for secure fit.
- Secure connector to the wiring harness below with 2 cable ties.
- Place the relay -3- back in the retainer with the base.
- Pull the foam tube -191 971 790 A- above the relay with base -6- of the fitting kit and secure with two cable ties.

- Place the relay with base -6- into the relay and fuse carrier as shown in the illustration.
- If necessary, route the connecting cable for the front left seat -5- along the original wiring harness to the seat's adapter.
- If necessary, route the connecting cable for the front right seat out of the relay and fuse carrier along the centre console -arrows- and the original wiring harness to the seat's adapter.

 **Note**

The connecting cable to the front right seat can be pushed under the centre console without any extra safety.

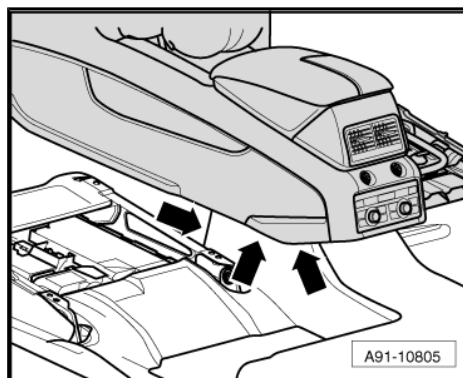

- Route the earth cable (brown) on the original wiring harness along the sill to the left earth point in the 2nd seat row -arrow-.

Specified torque 9 Nm

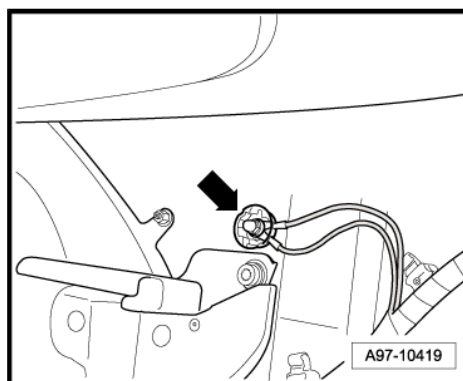

2.3 Mount retainer on seat and connect cables

- Route the cable to the retainer along the original wiring harness.

The cable route in the backrest is always on the left hand side.

- Bend the connections on the charging socket -4- by 90° -arrow-.
- Loosen nuts -2-. Pull the washer -3- up and push the charging socket -4- into the retainer -1- sideways. Hold the charging socket in this position and tighten the nut.

Specified torque 0,4 Nm

- Ensure that the charging socket is in the middle of the retainer after tightening.

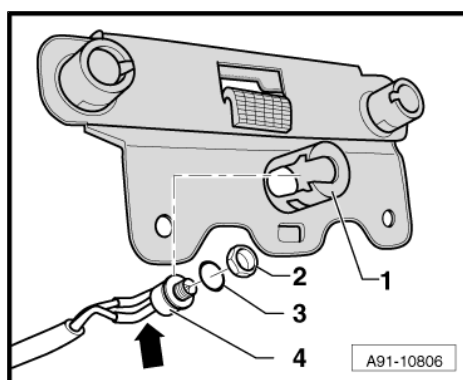

- Push the retainer -1- up inbetween seat frame and seat cover until it reaches over the top edge of the backrest frame with its edge -a-.
- Align the retainer so that it is in the centre and screw it onto the backrest frame -b-.

Specified torque 4,5 Nm

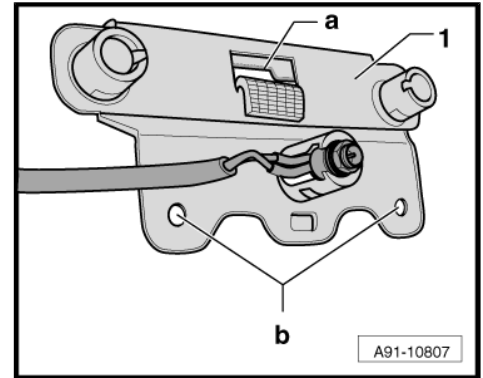

- Place the clip -1- into the hole -2- in the top area of the backrest.

 **Note**

- ◆ *Route the cables in such a way that they can follow every movement of the seat.*
- ◆ *Ensure that the cables cannot be trapped or damaged by sharp edges.*

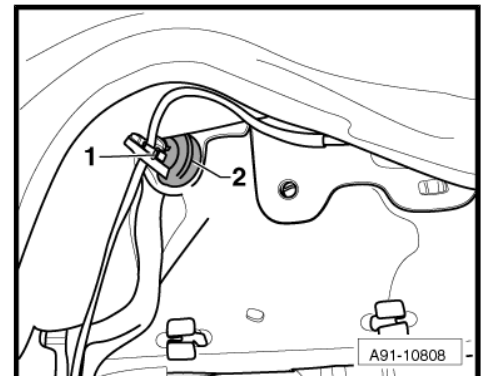

- Fasten the cable in the backrest to the side lugs -arrows- with cable ties.
- Bring the seat cover back in installation position and align.

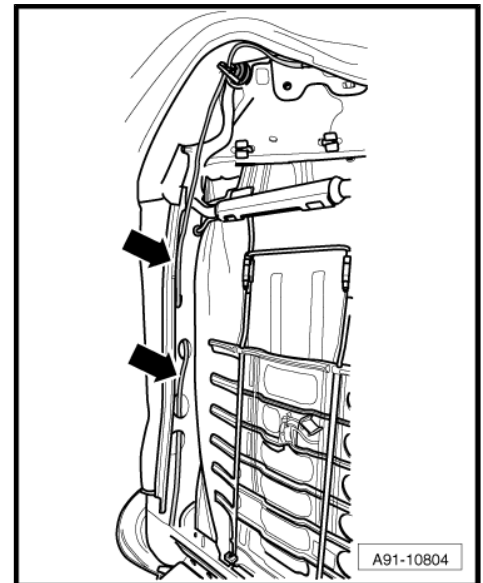

- Place the template at the top of the aperture of the head restraint guides -1-.
- Hold the template by the bottom edge and ensure it is flush with the edge of the seat frame -2- and mark the positions of the cutting areas on the seat cover -3-.
- Remove the template and carefully cut the openings in the area of the marks.

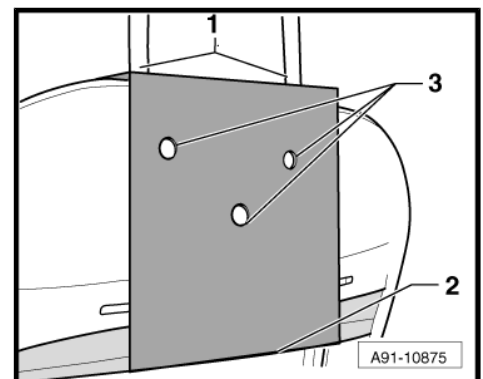

- Clean the area of the retainer -2- thoroughly.

 **Note**

Fabric rests in the retainers -2- prevent secure fitting of the guides -3-.

- Align the seat cover.
- Place the guides -3- into the retainers -2- and the cover -2- on the charging socket -1-.
- Ensure that the guides and the cover engage correctly (audibly) (twice each).

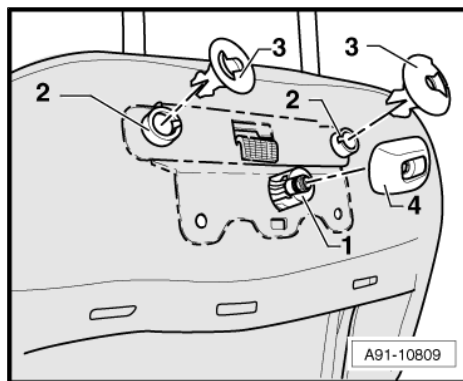

 **Note**

The press pieces of the guides -3- each point to the outside, the flat side of the cover -4- points to the right.

2.4 Final checks

Installation is carried out in reverse order of removal.

- Mount the DVD player to the seat according to the supplied manual.
- Give the driver the operating instructions „Mounting the DVD player on the seat“.